

DR 433

11.5 HP Regenerative Blower

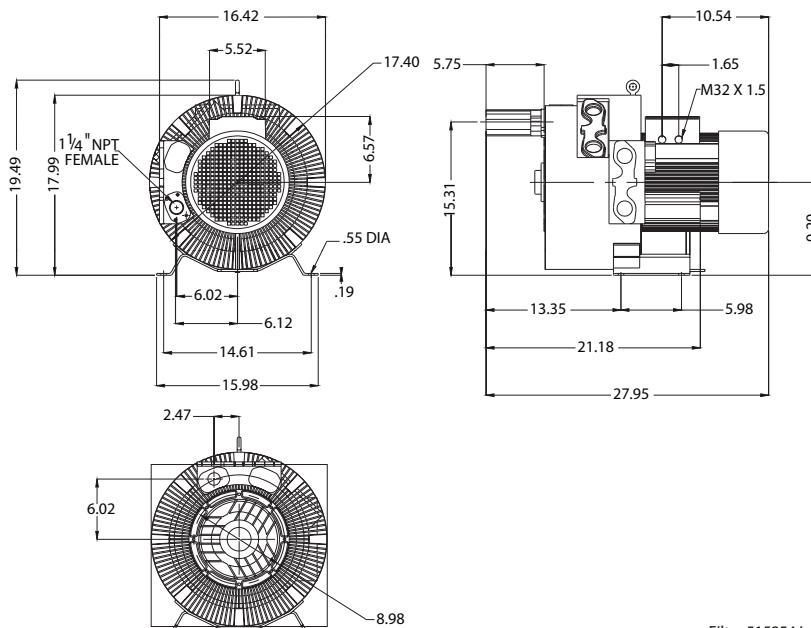

Filter 515254 included

		Part/ Model Number
		DR433GE72M
		081958
Specification	Units	
Motor Enclosure - Shaft Mtl.	-	TEFC-CS
Horsepower	-	11.5
Voltage	AC	208-230/460
Phase - Frequency	-	Three - 60 Hz
Insulation Class	-	F
NEMA Rated Motor Amps	Amps (A)	17.3/10
Service Factor	-	1.0
Locked Rotor Amps	Amps (A)	294/147
Max. Blower Amps	Amps (A)	22/11
Recommended NEMA Starter Size		3/2
Shipping Weight	Lbs	300
	Kg	136.1

Voltage - ROTRON motors are designed to handle a broad range of world voltages and power supply variations. Our dual voltage 3 phase motors are factory tested and certified to operate on both: **208-230/415-460 VAC-3 ph-60 Hz** and **190-208/380-415 VAC-3 ph-50 Hz**. Our dual voltage 1 phase motors are factory tested and certified to operate on both: **104-115/208-230 VAC-1 ph-60 Hz** and **100-110/200-220 VAC-1 ph-50 Hz**. All voltages above can handle a ±10% voltage fluctuation. Special wound motors can be ordered for voltages outside our certified range.

Operating Temperatures - Maximum operating temperature: Motor winding temperature (winding rise plus ambient) should not exceed 140°C for Class F rated motors or 120°C for Class B rated motors. Blower outlet air temperature should not exceed 140°C (air temperature rise plus inlet temperature). Performance curve maximum pressure and suction points are based on a 40°C inlet and ambient temperature. Consult factory for inlet or ambient temperatures above 40°C.

Maximum Blower Amps - Corresponds to the performance point at which the motor or blower temperature rise with a 40°C inlet and/or ambient temperature reaches the maximum operating temperature.

This document is for informational purposes only and should not be considered as a binding description of the products or their performance in all applications. The performance data on this page depicts typical performance under controlled laboratory conditions. AMETEK is not responsible for blowers driven beyond factory specified speed, temperature, pressure, flow or without proper alignment. Actual performance will vary depending on the operating environment and application. AMETEK products are not designed for and should not be used in medical life support applications. AMETEK reserves the right to revise its products without notification. The above characteristics represent standard products. For product designed to meet specific applications, contact AMETEK Technical & Industrial Products Sales department.

DR 433

11.5 HP Regenerative Blower

FEATURES

- ISO 9001 compliant
- CE compliant - Declaration of Conformity on file
- Maximum flow : 110 SCFM
- Maximum pressure: 13 PSIG (360 IWG)
- Maximum vacuum: 17.6 IHG (183 IWG)
- Standard motor: 11.5 HP, TEFC
- Cast aluminum blower housing, impeller & cover
- Cast Iron flanges (threaded)
- UL approved motor with permanently sealed ball bearings
- Inlet & outlet internal muffling
- Quiet operation within OSHA standards

MOTOR OPTIONS

- International voltage & frequency (Hz)

BLOWER OPTIONS

- Slip-on or face flanges for application-specific needs

ACCESSORIES

- Flowmeters reading in SCFM
- Filters & moisture separators
- Pressure gauges, vacuum gauges, & relief valves
- External mufflers for additional silencing
- Air knives (used on blow-off applications)
- Variable frequency drive package

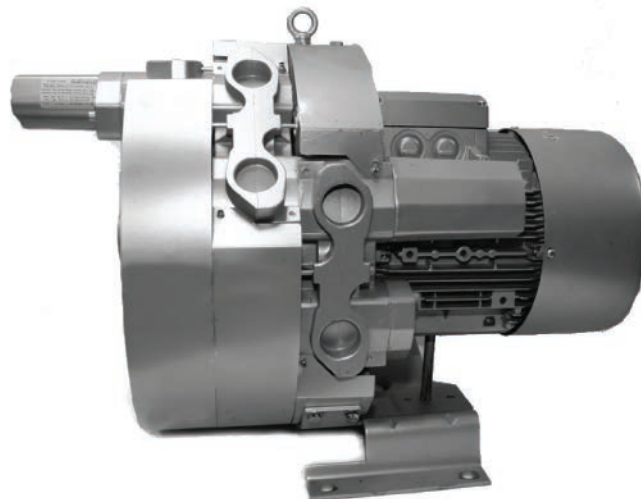

Blower Performance at Standard Conditions

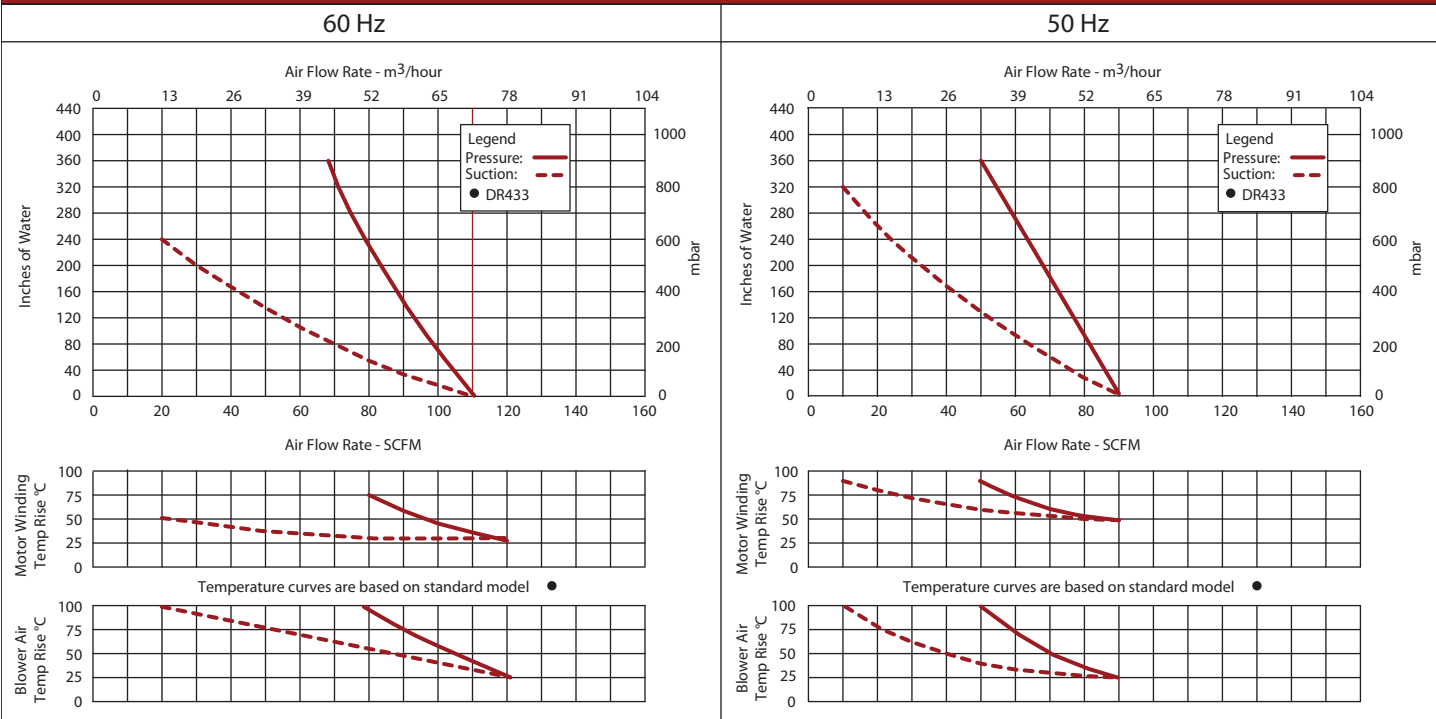

This document is for informational purposes only and should not be considered as a binding description of the products or their performance in all applications. The performance data on this page depicts typical performance under controlled laboratory conditions. AMETEK is not responsible for blowers driven beyond factory specified speed, temperature, pressure, flow or without proper alignment. Actual performance will vary depending on the operating environment and application. AMETEK products are not designed for and should not be used in medical life support applications. AMETEK reserves the right to revise its products without notification. The above characteristics represent standard products. For product designed to meet specific applications, contact AMETEK Technical & Industrial Products Sales department.